

USER MANUAL

The manufacturer reserves the right to make changes to the Ninebot S-PRO, release firmware updates, and update this manual at any time. Visit www.segway.com to download the latest user materials and watch the safety video. You must install the Segway-Ninebot App to follow the New Rider Tutorial, activate your Ninebot S-PRO, and obtain the latest updates and safety instructions.

www.segway.com

01.07.0269.00-B

ninebot[®] S-PRO

Content

1 Riding Safety	01
2 Packing List	03
3 Diagram	04
4 Icons on the Dashboard	05
5 Assemble Your Ninebot S-PRO	06
6 Charging	07
7 First Ride	08
8 Learning to Ride	09
9 Warning	11
10 Lifting and Assistance Mode	13
11 Maintenance	14
12 Specifications	16
13 Trademark and Legal Statement	17
14 Certifications	18
15 Contact	20

Thanks for choosing Ninebot S-PRO!

Thanks for choosing Ninebot Personal Transportation Robot (Ninebot S-PRO)!

Enjoy your free ride now!

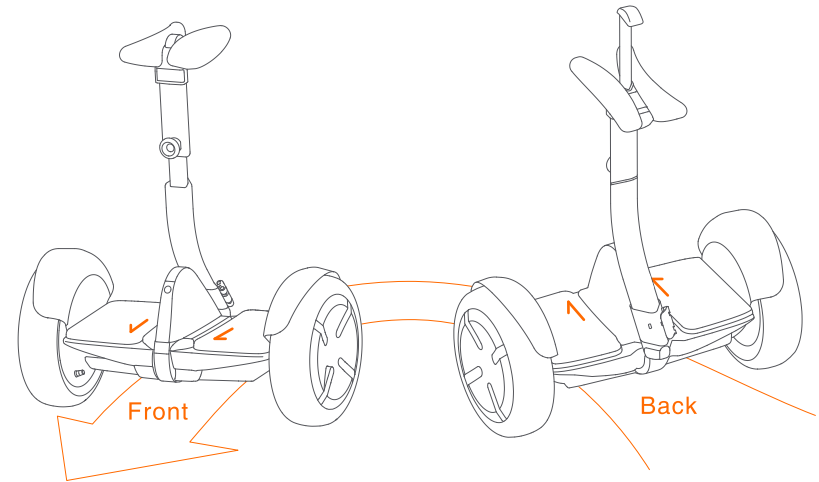

Hint: Please step on/off from the Back!
Otherwise you risk falls and/or collisions because the steering direction is reversed!

1 Riding Safety

1. The Ninebot S-PRO is a recreational product. Before mastering riding skills, you need to practice. Neither Ninebot (means Ninebot (Beijing) Tech Co., Ltd. and its subsidiaries and affiliates) nor Segway Inc. is responsible for any injuries or damage caused by a rider's inexperience or failure to follow the instructions in this document.
2. Please understand that you can reduce the risk by following all the instructions and warnings in this manual, but you cannot eliminate all the risks. Remember that whenever you ride the Ninebot S-PRO you risk injury or death from loss of control, collisions, and falls. When entering into public spaces always comply with the local laws and regulations. As with other vehicles, faster speeds require longer braking distance. Sudden braking on smooth surfaces could lead to wheel slip, loss of balance, or falls. Be cautious and always keep a safe distance between you and other people or vehicles when riding. Be alert and slow down when entering unfamiliar areas.
3. Always wear a helmet when riding. Use an approved bicycle or skateboard helmet that fits properly with the chin strap in place, and provides protection for the back of your head.
4. Do not attempt your first ride in any area where you might encounter children, pedestrians, pets, vehicles, bicycles, or other obstacles and potential hazards.
5. Respect pedestrians by always yielding the right of way. When approaching a pedestrian from the front, stay to the right and slow down. Avoid startling pedestrians. When approaching from behind, announce yourself and slow down to walking speed when passing. Pass on the left whenever possible. Please obey local traffic laws and regulations.
6. In places without laws and regulations governing self-balancing electric vehicles, comply with the safety guidelines outlined in this manual. Neither Ninebot nor Segway Inc. is responsible for any property damage, personal injury/death, accidents, or legal disputes caused by violations of the safety instructions.
7. Do not allow anyone to ride your Ninebot S-PRO on his/her own unless he/she has carefully read this manual, watched the safety video, and followed the New Rider Tutorial on the Segway-Ninebot App. The safety of new riders is your responsibility. Assist new riders until they are comfortable with the basic operation of the Ninebot S-PRO. Make sure each new rider wears a helmet and other protective gear.
8. Before each ride check for loose fasteners, damaged components, and low tire pressure. If the Ninebot S-PRO makes abnormal sounds or signals an alarm, immediately stop riding. Diagnose your Ninebot S-PRO via the Segway-Ninebot App and call your dealer/distributor for service.
9. Be alert! Scan both far ahead and in front of your Ninebot S-PRO — your eyes are your best tool for safely avoiding obstacles and low traction surfaces (including, but not limited to, wet ground, loose sand, loose gravel, and ice).
10. To reduce risk of injury, you must read and follow all "CAUTION" and "WARNING" notices in this document. Do not ride at an unsafe speed. Under no circumstance should you ride on roads with motor vehicles. The manufacturer recommends riders be 16+ years old. Always follow these safety instructions:
 - A. People who should not ride the Ninebot S-PRO include:
 - i. Anyone under the influence of alcohol or drugs.
 - ii. Anyone who suffers from disease that puts them at risk if they engage in strenuous physical activity.
 - iii. Anyone who has problems with balance or with motor skills that would interfere with their ability to maintain balance.
 - iv. Anyone whose height or weight is outside the stated limits (see Specifications).
 - v. Pregnant women.
 - B. Riders under the age of 18 years old should ride under adult supervision.
 - C. Comply with local laws and regulations when riding this product. Do not ride where prohibited by local laws.
 - D. To ride safely, you must be able to clearly see what is in front of you and you must be clearly visible to others.
 - E. Do not ride in the snow, in the rain, or on roads which are wet, muddy, icy, or that are slippery for any reason. Do not ride over obstacles (sand, loose gravel, or sticks). Doing so could result in a loss of balance or traction and could cause a fall.
 - F. Do not accelerate or decelerate suddenly. Do not accelerate when the Ninebot S-PRO tilts back or sounds an alarm. Do not attempt to override the speed limiter.
11. Do not attempt to charge your Ninebot S-PRO if it, the charger, or the power outlet is wet.
12. As with any electronic device, use a surge protector when charging to help protect your Ninebot S-PRO from damage due to power surges and voltage spikes. Only use the Ninebot supplied charger. Do not use a charger from any other product.
13. Use only Ninebot or Ninebot approved parts and accessories. Do not modify your Ninebot S-PRO. Modifications to your Ninebot S-PRO could interfere with the operation of the Ninebot S-PRO, could result in serious injury and/or damage, and could void the Limited Warranty.
14. Do not sit on the steering bar. Doing so could result in serious injury and/or damage to your Ninebot S-PRO.

2 Packing List

Knee Control Bar

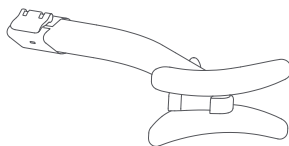

User Manual



Quick Start



Limited Warranty



Accessory Box



Accessories in the Box

Battery Charger

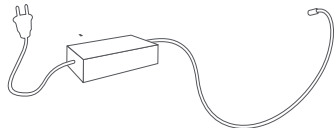

Valve Stem Extension



Mainframe

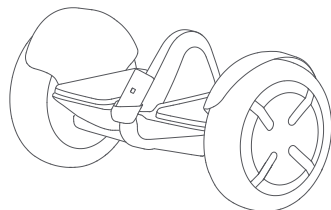

When unpacking your Ninebot S-PRO, please verify that the above items are included in the package. If you are missing any components, please contact your dealer/distributor or visit website: www.segway.com. After verifying that all components are present and in good condition, you can assemble your new Ninebot S-PRO.



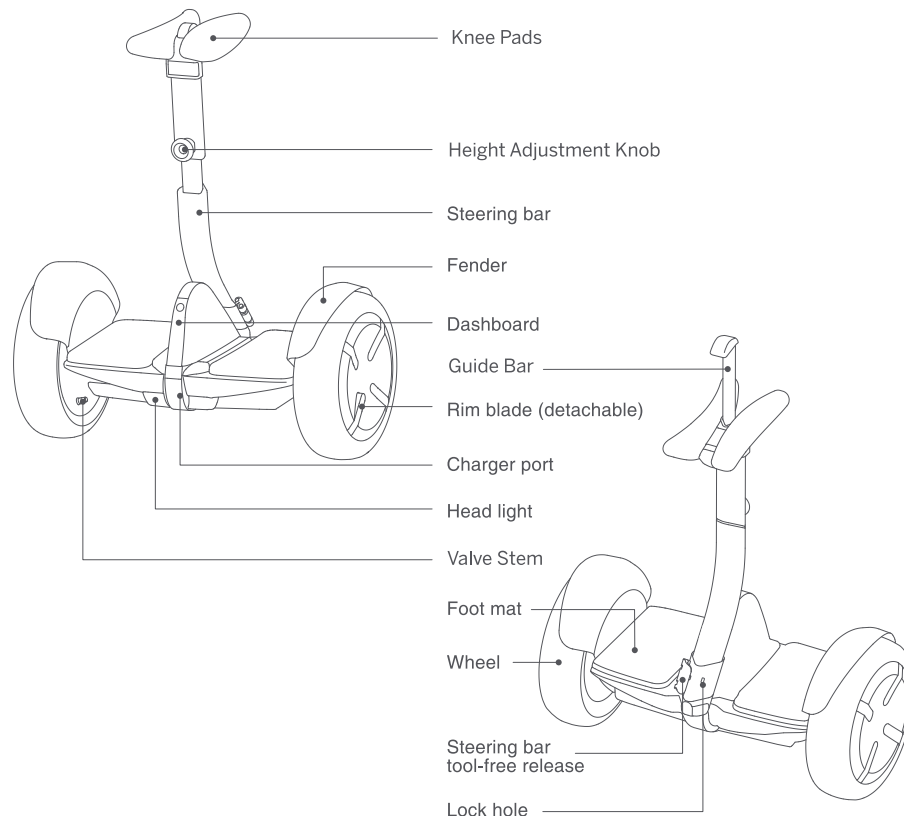

Always power off your Ninebot S-PRO and unplug the charge cable before assembling, mounting accessories, or cleaning.

3 Diagram

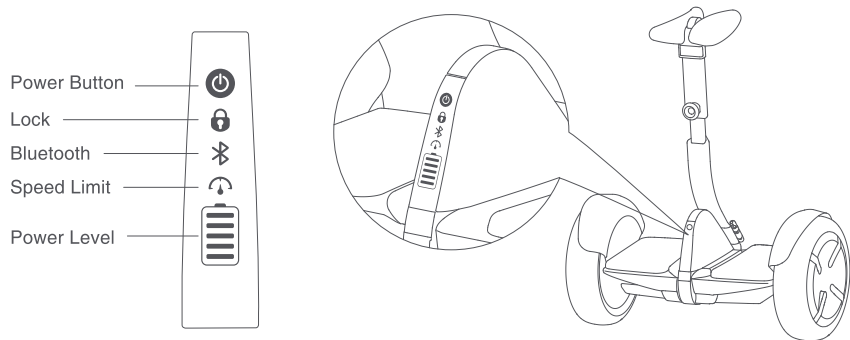

4 Icons on the Dashboard



	Power Button	Power ON/OFF. The Ninebot S-PRO will automatically power OFF when idle for 10 minutes, or when laid down (horizontal) for over 5 seconds.
	Lock	The Ninebot S-PRO will vibrate and buzz alarm if anyone moves it when Lock Mode is activated by App. User's smart phone will automatically alarm at the same time if App is running.
	Bluetooth	The Bluetooth icon flicker to indicate the Bluetooth is ON but not connected to your App; Bluetooth icon light staying ON indicates the Segway-Ninebot App has connected to Ninebot S-PRO.
	Speed Limit	The Ninebot S-PRO will be limited to lower speed when Speed Limit icon is ON, user will feel Foot Mat tilting up when accelerating. Default speed limit is 4.3 mph (7 km/h), and can be adjusted by App.
	Power Level	Indicates the remaining battery stamina->level. Whenever the Ninebot S-PRO notifies you of an empty Battery condition (power icon flickers), you need to charge your Ninebot S-PRO. Use your App to read the remaining power and estimated drivable mileage->range. when the reading is less than 30%, your Ninebot S-PRO will gradually reduce the max speed limit and when less than 10%, you can only reach 4.3 mph (7 km/h).

5 Assemble Your Ninebot S-PRO

Install the knee control bar

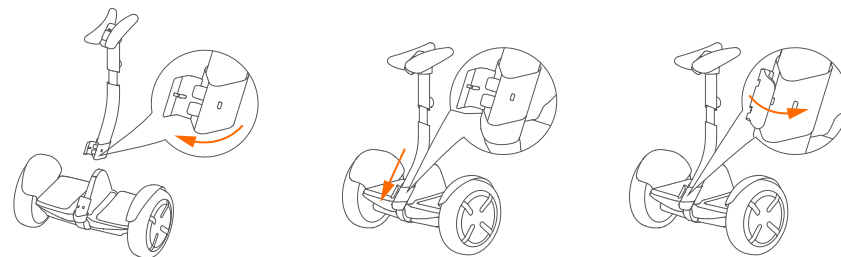

Open the tool-free release of the steering bar

Insert the steering bar to the mainframe steering socket

Fasten quick release

Check the Power ON/OFF status after assembly.

For your safety, your Ninebot S-PRO is not activated at this time and will beep occasionally after Power ON. Until activated, the Ninebot S-PRO maintains a very low riding speed and steering sensitivity, and should not be ridden.

Install the Segway-Ninebot App on your smart phone (with BLE 4.0 or above), connect to the Ninebot S-PRO with Bluetooth, and follow the App instructions to activate your Ninebot S-PRO.

Height adjustment of the knee pads

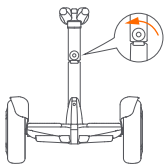

Rotate height adjustment knob anticlockwise

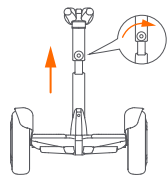

Lift knee pads to suitable height. Tighten up height adjustment knob clockwise

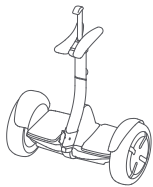

The guide bar can be lifted to help you push the Ninebot S-PRO when Power ON

6 Charging

⚠ Do not connect the charger if the charge port or charge cable is wet.

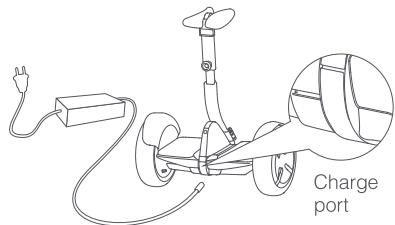

Charge port

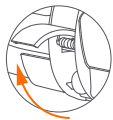

Open the cap

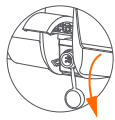

Open the rubber cap



Insert the plug into the socket

When the scooter is not powered on for ten consecutive days and its battery level is under 20%, the battery will enter into sleep mode. If this happens, your scooter cannot be powered on. Please charge it to activate the battery promptly.



+



×

10



=

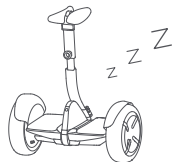

7 First Ride



There are safety risks for a new rider when learning to ride the Ninebot S-PRO. You must follow the New Rider Tutorial before your first ride.

Scan the QR code to install Segway-Ninebot App.

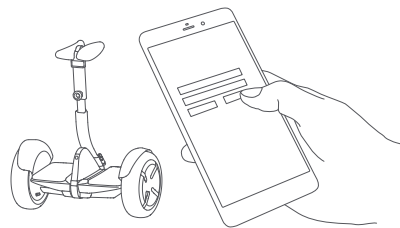

1. Install the App and register/log in.

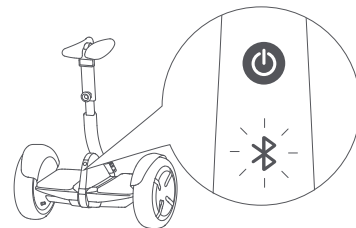

2. Power on, Bluetooth icon flickering indicates the Ninebot S-PRO waiting for connection.

3. Click Vehicle button to connect. Your Ninebot S-PRO will beep once when the Bluetooth connection is successful and the Bluetooth icon will be ON.

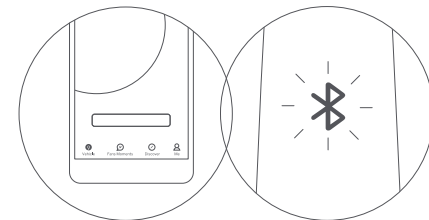

Please strictly follow the App instructions to learn how to ride safely & have fun.

8 Learning to Ride



Warning

Rider must weigh 85-220 lbs (40-100 kg) and must be 4'3"-6'6" (130-200 cm) tall.

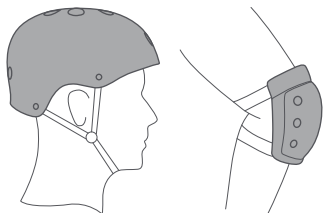

Wear an approved helmet and other protective gear to minimize any possible injury.

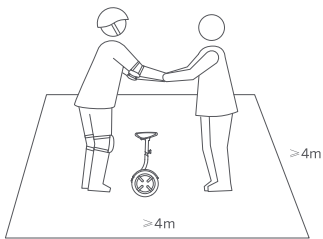

1. Go to a large open area and ask a friend to assist you on your first ride.



WARNING

Always step on/off from the back of the Ninebot S-PRO.

After activation, the App will lead you through the New Rider Tutorial. Please follow the instructions in the App and in this manual.

NOTE

You must first download the Segway-Ninebot App on your mobile device. The App will lead you through the New Rider Tutorial.

For your safety, the Ninebot S-PRO will limit the max speed to 4.3 mph (7 km/h) until you complete the New Rider Tutorial. For the first 0.6 miles (1 km) after completing the New Rider Tutorial, the max speed will be limited to 6.2 mph (10 km/h), after which you can disable the speed limiter via the App and reach a maximum speed of 11.2 mph (18 km/h).

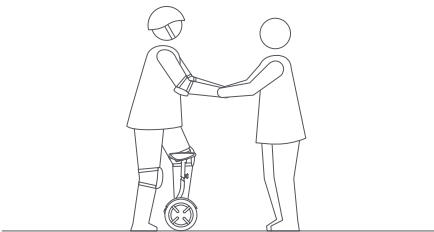

2. Lightly place one foot on the foot mat, while keeping your other foot on the ground holding your weight. Do not press the knee pad with your knees to avoid steering.

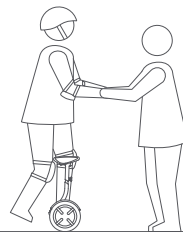

3. Slowly transfer your weight onto the foot mat. Slowly step on with your other foot.

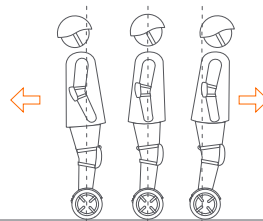

5. Gently lean your body forward and backward to control your movement.

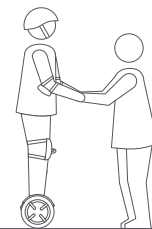

4. Stand with your weight evenly distributed on both feet and relax, looking straight ahead. Avoid sudden steering.

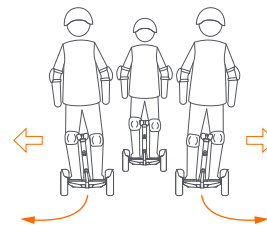

6. To turn, gently lean left or right against the steering bar/knee pads.

9 Warning

- ⚠ You must read and understand the Warnings and Riding Safety instructions in this manual before attempting to ride the Ninebot S-PRO. Failure to follow these warnings could result in death or serious injury due to: loss of balance, traction, and/or control; collisions; and falls.

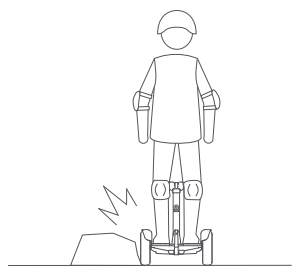

- ⚠ Avoid contacting obstacles with the tire/wheel.

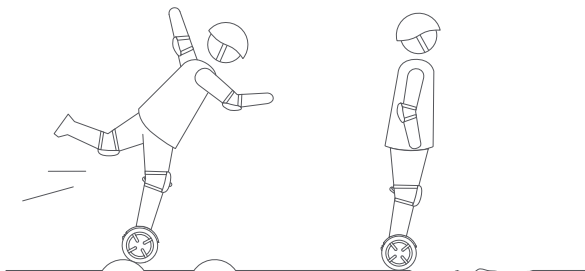

- ⚠ When traversing small bumps or uneven terrain, maintain a moderate speed of 2-6 mph (3-10 km/h) and keep your knees bent. Do not go too slow or too fast; otherwise you may lose control and fall.

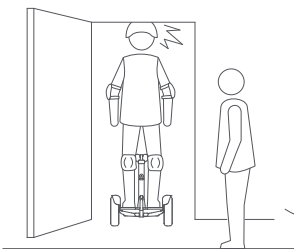

- ⚠ Watch your head when passing through doorways.

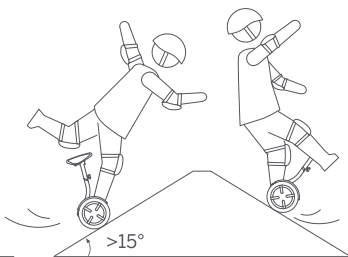

- ⚠ Avoid slopes steeper than 15°.

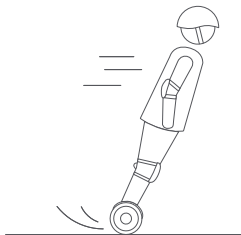

- ⚠ Avoid abrupt accelerating or decelerating

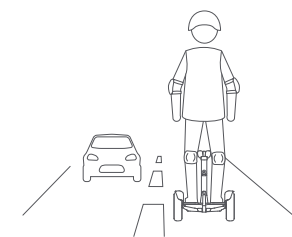

- ⚠ Do not ride on public roads, motorways, highways, or streets.

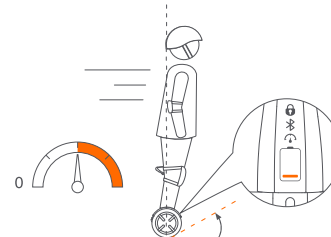

- ⚠ Do not accelerate when the Ninebot S-PRO tilts back or sounds an alarm. Do not attempt to override the speed limiter.



- ⚠ Do not ride through puddles or other bodies of water. Do not get wet.

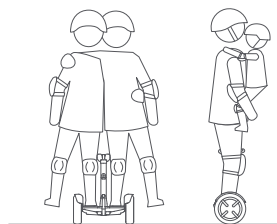

- ⚠ The Ninebot S-PRO is for one rider only. Do not ride double or carry any passengers. Do not carry a child.

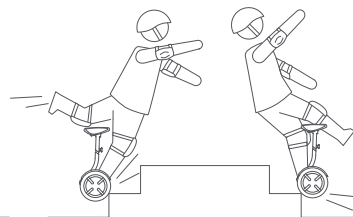

- ⚠ Do not ride over holes, curbs, steps, or other obstacles.

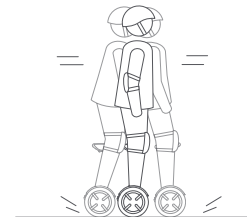

- ⚠ Do not rock back and forth or shift your weight abruptly.

10 Lifting and Assistance Mode

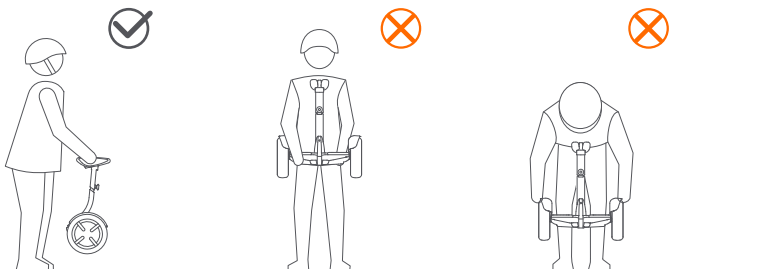

Lifting

When your Ninebot S-PRO is Power ON and lifted, it will automatically cut off power output for your safety. The power will be automatically restored once it is placed back onto the ground. Do not lift the Ninebot S-PRO by the fenders or the main frame. Otherwise, you will risk serious injury of your clothes or fingers being trapped between the tire and the fenders. As shown above.

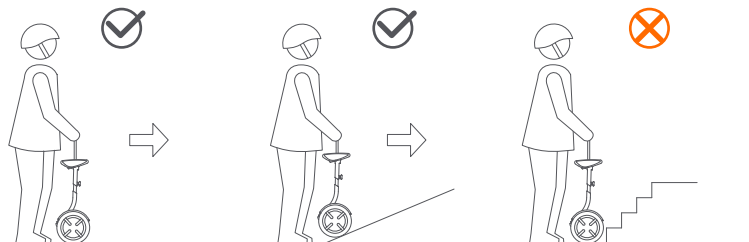

Power Assist

When your Ninebot S-PRO is powered on, no rider is standing on it, it is in Power Assist Mode. Steer the Ninebot S-PRO across smooth surfaces using the steering bar. Do not guide it up stairs, across potholes, over large cracked/uneven surfaces, or over other obstacles; guide your Ninebot S-PRO around the obstacle or carry it over the obstacle as shown above.

11 Maintenance

Cleaning and Storing Your Ninebot S-PRO

Use a soft, wet cloth to wipe the mainframe clean. Hard to remove dirt can be scrubbed with a toothbrush and toothpaste, then cleaned with a soft, wet cloth.

NOTE

The IP Rating of the mainframe is IP54, IP Rating of the battery pack is IPX6. Do not wash your Ninebot S-PRO with alcohol, gasoline, acetone, or other corrosive/volatile solvents. These substances may damage the appearance and internal structure of your Ninebot S-PRO. Do not wash your Ninebot S-PRO with a power washer or high pressure hose.

⚠ WARNING

Make sure the Ninebot S-PRO is powered OFF, the charging cable is unplugged, and the rubber cap on the charge port is tightly sealed before cleaning; otherwise you may expose yourself to electric shock or damage the electronic components. Store your Ninebot S-PRO in a cool, dry place. Do not store it outdoors for extended periods of time. Exposure to sunlight and extreme temperature (both hot and cold) will accelerate the aging process of the plastic components and may reduce battery life.

Battery Pack Maintenance

Do not store or charge the battery at temperatures outside the stated limits (see Specifications). Do not expose the battery to fire. Do not discard or destroy the battery. Refer to your local laws and regulations regarding battery recycling and/or disposal.

A well maintained battery can perform well even after many miles of riding. Charge the battery after each ride and avoid draining the battery completely. When used at room temperature (70°F [22°C]) the battery range and performance is at its best; whereas using it at temperatures below 32°F (0°C) can decrease range and performance. Typically, at -4°F (-20°C) range can be half that of the same battery at 70°F (22°C). Battery range will recover when temperature rises.

NOTE

Typically, a fully charged battery should retain charge for 120-180 days in Standby Mode. Remember to charge the battery after each use. Completely draining the battery may cause permanent damage to the battery. Electronics inside the battery record the charge-discharge condition of the battery; damage caused by over-charging or under-charging will not be covered by the Limited Warranty.

⚠ WARNING

Do not attempt to disassemble the battery. Risk of fire. No user serviceable parts.

⚠ WARNING

Do not ride when the ambient temperature is outside the machine operation temperature (see Specifications) because low/high temperature will limit the maximum power/torque. Doing so could cause personal injury or property damage due to slips or falls.

Recommended tire pressure

Inflate tires to 45–50 psi. Inflate both tires equally.

12 Specifications

Index	Items	N3M320 Parameters
Dimension	L × W	21.5 × 10.3 in (546 × 262 mm)
	Mainframe H ^[1]	25 - 37 in (645 - 955 mm)
Weight	Payload	85 - 220 lbs (40 - 100 kg)
	Net	Approx. 28 lbs (12.8 kg)
Rider	Recommended Age	16 - 50 years
	Required Height	4'3"-6'6" (120 - 200 cm)
Machine Parameter	Max. Speed	Approx. 11.2 mph (18 km/h)
	Typical Range ^[2]	Approx. 18.6 miles (30 km)
	Max. Slope	Approx. 15°
	Beginner Mode	Can be disabled or reset by App after 0.6 mi (1 km) riding, accumulative riding, can be reset by App
	Traversable Terrain	Pavement, packed dirt, slopes < 15°, obstacles < 0.4 in (1 cm), gaps < 1.2 in (3 cm)
	Operating Temperature	14–104°F (-10–40°C)
	Storage Temperature	-4–122°F (-20–50°C)
	IP Rating	IP54
Battery Pack	Charge Time	Approx. 4 h
	Nominal Voltage	54.3 V ---
	Max. Charging Voltage	63 V ---
	Nominal Capacity	310 Wh
Motor	Smart BMS	Overvoltage / Undervoltage / Short Circuit / Overheating Protection. Auto-Sleep / Wake-up, detailed information of battery can be checked with Segway-Ninebot App
	Nominal Power	400 x 2 W
	Max. Power	800 x 2 W
Charger	Compliance	CCC, CE
	Output Power	120 W
	Input Voltage	100–240V~ 50/60 Hz
	Output Voltage	Approx. 63 VDC
Charger	Output Current	Approx. 2.0 A

[1] Mainframe height: refers to distance from ground to the highest end of mainframe.

[2] Typical Range: tested while riding under full power, 154 lbs (70 kg) load, 77°F (25°C), 9.3 mph (15 km/h) average speed on pavement.

13 Trademark and Legal Statement

Ninebot is registered trademark of Ninebot (Tianjin) Tech. Co., Ltd; Ninebot S-PRO is trademark of Ninebot (Tianjin) Tech. Co., Ltd; Segway is registered trademark of Segway Inc; Apple and Apple Logo are registered trademark of Apple Inc in the United States and elsewhere. App Store is service mark of Apple Inc; Android is trademark of Google Inc, Android robots was originally created by Google Inc; The respective owners reserve the rights of their trademarks referred to in this manual.

© 2018 Ninebot (Beijing) Tech Co., Ltd. All rights reserved.

The Ninebot S-PRO is covered by relevant patents. For patent information go to <http://www.segway.com>.

We have attempted to include descriptions and instructions for all the functions of the Ninebot S-PRO at the time of printing. However, due to constant improvement of product features and changes of design, your Ninebot S-PRO may differ slightly from the one shown in this document.

Please note that there are multiple Ninebot models with different functions, and some of the functions mentioned herein may not be applicable to your unit. The manufacturer reserves the right to change the design and functionality of the Ninebot S-PRO product and documentation without prior notice.

14 Certifications

Important WEEE information



WEEE Disposal and Recycling Information Correct Disposal of this product. This marking indicates that this product should not be disposal with other household wastes throughout the EU.

To prevent possible harm to the environment or human health from uncontrolled waste disposal, recycle it responsible to promote the sustainable reuse of materials resources. To return your used device, please use the return and collection systems or contact the retailer where the product was purchased. They can take this product for environmental safe recycling.

Battery recycling information for the European Union



Batteries or packaging for batteries are labeled in accordance with European Directive 2006/66/EC concerning batteries and accumulators and waste batteries and accumulators. The Directive determines the framework for the return and recycling of used batteries and accumulators as applicable throughout the European Union. This label is applied to various batteries to indicate that the battery is not to be thrown away, but rather reclaimed upon end of life per this Directive.

In accordance with the European Directive 2006/66/EC, batteries and accumulators are labeled to indicate that they are to be collected separately and recycled at end of life. The label on the battery may also include a chemical symbol for the metal concerned in the battery (Pb for lead, Hg for mercury, and Cd for cadmium). Users of batteries and accumulators must not dispose of batteries and accumulators as unsorted municipal waste, but use the collection framework available to customers for the return,

recycling, and treatment of batteries and accumulators. Customer participation is important to minimize any potential effects of batteries and accumulators on the environment and human health due to the potential presence of hazardous substances.

Before placing electrical and electronic equipment (EEE) in the waste collection stream or in waste collection facilities, the end user of equipment containing batteries and/or accumulators must remove those batteries and accumulators for separate collection.

Restriction of Hazardous Substances (RoHS) Directive

This Ninebot (Tianjin) Tech Co., Ltd. product, with included parts (cables, cords, and so on) meets the requirements of Directive 2011/65/EU on the restriction of the use of certain hazardous substances in electrical and electronic equipment ("RoHS recast" or "RoHS 2").

Radio Equipment Directive



Segway Europe BV, Hogehilweg 8, 1101 CC Amsterdam, The Netherlands

Hereby, Ninebot (Tianjin) Tech Co., Ltd, declares that the wireless equipment listed in this section are in compliance with the essential requirements and other relevant provisions of Directive 2014/53/EU. Maximum radio-frequency power: 100mW Frequency bands: 2.400 to 2.4835 GHz.

15 Contact

Contact us if you experience issues relating to riding, maintenance and safety, or errors/faults with your Ninebot S-PRO.

Segway Europe B.V.
Hogehilweg 8, 1101CC Amsterdam, The Netherlands
Website: www.segway.com

Have your Ninebot S-PRO serial number on hand when contacting Segway.

You can find your serial number on the underside of your Ninebot S-PRO or in the App under More Settings → Basic Information.